

Please check the examination details below before entering your candidate information

Candidate surname

Other names

Centre Number

Candidate Number

--	--	--	--	--

--	--	--	--

Pearson Edexcel International GCSE (9-1)

Time 1 hour 15 minutes

Paper
reference

4BI1/2B

Biology

UNIT: 4BI1

PAPER: 2B

You must have:

Calculator, ruler

Total Marks

Instructions

- Use **black** ink or ball-point pen.
- If pencil is used for diagrams/sketches/graphs it must be dark (HB or B).
- **Fill in the boxes** at the top of this page with your name, centre number and candidate number.
- Answer **all** questions.
- Answer the questions in the spaces provided
– *there may be more space than you need.*
- Show all the steps in any calculations and state the units.

Information

- The total mark for this paper is 70.
- The marks for **each** question are shown in brackets
– *use this as a guide as to how much time to spend on each question.*

Advice

- Read each question carefully before you start to answer it.
- Try to answer every question.
- Check your answers if you have time at the end.

Turn over ►

P72473A

©2023 Pearson Education Ltd.

J:1/1/1/1/



Pearson

Answer ALL questions

Some questions must be answered with a cross in a box ☒. If you change your mind about an answer, put a line through the box ☒ and then mark your new answer with a cross ☒.

- 1 Read the passage below. Use the information in the passage and your own knowledge to answer the questions that follow.

Treating Kidney Disease

Chronic kidney disease affects approximately 12% of the world's population and many people are unable to obtain treatment. One method of treating chronic kidney disease is by dialysis. The diagram shows how kidney dialysis is done.

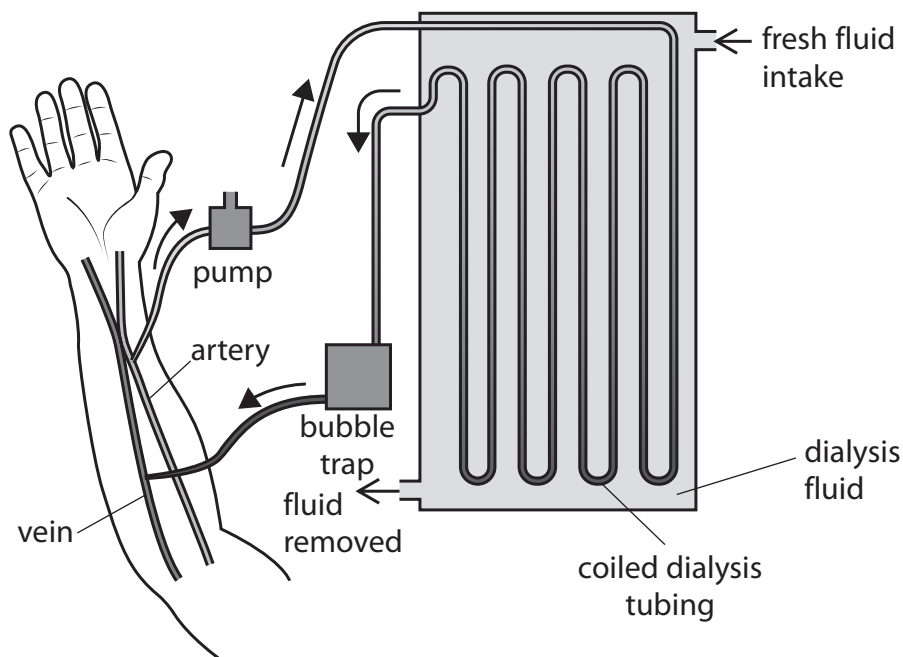

- During dialysis, blood is taken from an artery in the arm and is pumped through a dialyser. In the dialyser, the blood passes through a long, coiled dialysis tube made of a thin partially permeable membrane. The tube is surrounded by dialysis fluid. The dialysis fluid contains glucose and ions at concentrations normally found in blood plasma, but does not contain urea. The urea passes from the blood into the dialysis fluid. The temperature in the dialyser is kept at 40 °C. After passing through the dialyser, the blood is returned to a vein in the arm. Kidney dialysis can take up to three hours and must be done three times a week.

- Scientists have now designed a new bioartificial kidney. This artificial kidney is a combination of engineering and living cells. This artificial kidney has a haemofilter made from artificial membranes that filter the blood. The substances filtered out of the blood then pass through a device called a bioreactor. This bioreactor absorbs useful substances back into the blood. The bioreactor is made of living nephron cells that are grown from stem cells. These cells are separated from the patient's blood by a silicon membrane to prevent the immune system rejecting them. Bioartificial kidneys are the same size as a human kidney and will be fitted inside the body to replace a kidney. The bioartificial kidney can react to changes in the body in the same way as a normal kidney.



(d) (i) The haemofilter in the bioartificial kidney filters the blood (Lines 13 and 14).

Where does ultrafiltration occur in a nephron?

(1)

- A** Bowman's capsule
- B** collecting duct
- C** distal convoluted tubule
- D** loop of Henle

(ii) The cells in the bioreactor absorb glucose from the filtrate in a way that is similar to the cells in a nephron (Lines 14 to 17).

Describe how the nephron absorbs glucose back into the blood from the filtrate.

(2)

.....

.....

.....

.....

(iii) The bioartificial kidney is connected to blood vessels and to the tube that transports urine to the bladder in the same way as the human kidney.

Which row of the table is correct?

(1)

	Blood vessel bringing blood into bioartificial kidney	Tube transporting urine to bladder
<input type="checkbox"/> A	renal artery	ureter
<input type="checkbox"/> B	renal artery	urethra
<input type="checkbox"/> C	renal vein	ureter
<input type="checkbox"/> D	renal vein	urethra



2 (a) The diagram shows a human eye.

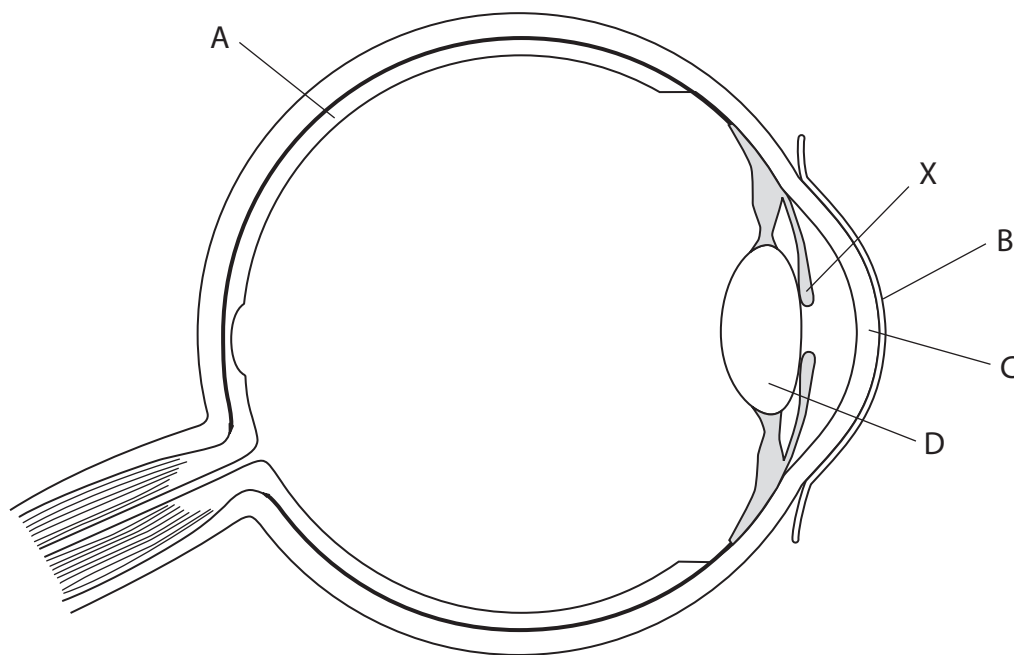

(i) Which labelled structure is the cornea?

(1)

- A
- B
- C
- D

(ii) Explain the changes in structure X as a person moves from a room where the light is dim to a room where the light is bright.

(2)

.....

.....

.....

.....



- (b) A student investigates if using one eye or using two eyes is better for judging the distance of objects.

The student uses the plastic block shown in the diagram. The block has a grid where six different coloured pins can be placed as shown in the diagram.

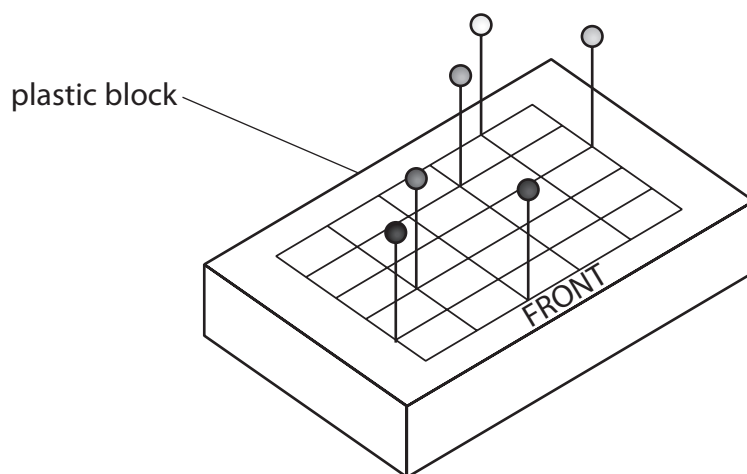

This is the student's method.

- place one pin into the lines of each column and row so that each pin is a different distance from the front of the grid
- ask a volunteer to close one eye
- hold the grid in front of the volunteer so they can see the coloured pins but not the grid
- ask the volunteer to call out the colour of the pins in order of distance, from nearest to furthest
- record the number of pins that the volunteer identifies correctly
- repeat eight more times, each time moving the pins to different positions in the grid

The student does the experiment again with both eyes open.

- (i) Give the independent variable for the student's investigation.

(1)

- (ii) Give one variable that the student should control.

(1)



(iii) Table 1 shows the student's results.

Complete Table 2 by determining the mode and the median for the data shown in Table 1.

(2)

Trial number	Number of correctly identified pins	
	Using one eye	Using both eyes
1	1	6
2	1	6
3	3	4
4	0	6
5	2	6
6	2	6
7	3	3
8	3	4
9	0	6

Table 1

	Number of correctly identified pins	
	Using one eye	Using both eyes
Mode		
Median		

Table 2



(iv) The field of view is the area that an animal can see with their eyes.
The diagram shows the field of view for a cat.

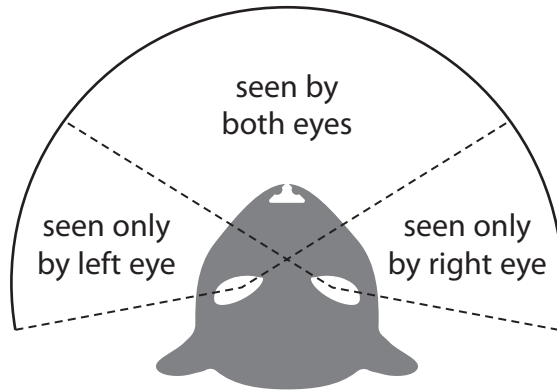

Explain why predators, such as cats, have two forward facing eyes.

Use the information in the diagram and Table 2 to support your answer.

(3)

.....

.....

.....

.....

.....

.....

(Total for Question 2 = 10 marks)

DO NOT WRITE IN THIS AREA

DO NOT WRITE IN THIS AREA

DO NOT WRITE IN THIS AREA



- 3 Hair colour in cattle is controlled by one gene with two alleles. The allele for white hair, C^W , is codominant with the allele for red hair, C^R .

Heterozygous cattle are a pale red colour called roan.

- (a) State what is meant by the term **gene**.

(1)

- (b) (i) Complete the table by giving the genotypes of red cattle, white cattle, and roan cattle.

(1)

Cattle hair colour	Genotype
red	
white	
roan	

- (ii) Two roan-coloured cattle are mated.

Determine the probability that the calf produced is a male calf with roan-coloured hair.

Include a genetic diagram in your answer.

(4)

probability =



- 4 Scientists have genetically modified soya plants so that the soya beans they produce contain less saturated fat.

The scientists produced one transgenic soya plant. Micropropagation was then used to make multiple copies of this transgenic soya plant.

- (a) Explain why micropropagation was used to produce copies of the transgenic soya plant.

(2)

- (b) A student uses this equipment to compare the energy content of transgenic soya beans with the energy content of non-transgenic soya beans.

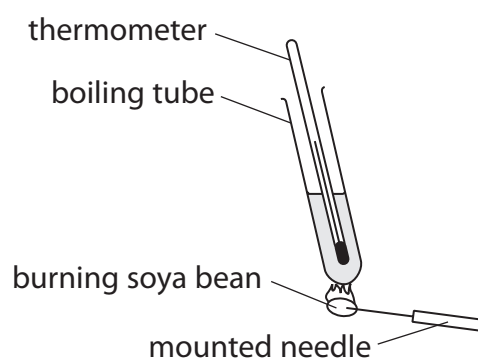

- (i) Describe how the student could use the equipment to make a valid comparison of the energy content of the two types of soya bean.

(4)



(ii) Give one safety precaution that the student should take when using the apparatus.

(1)

(iii) The diagram shows a different type of apparatus that can be used for the investigation.

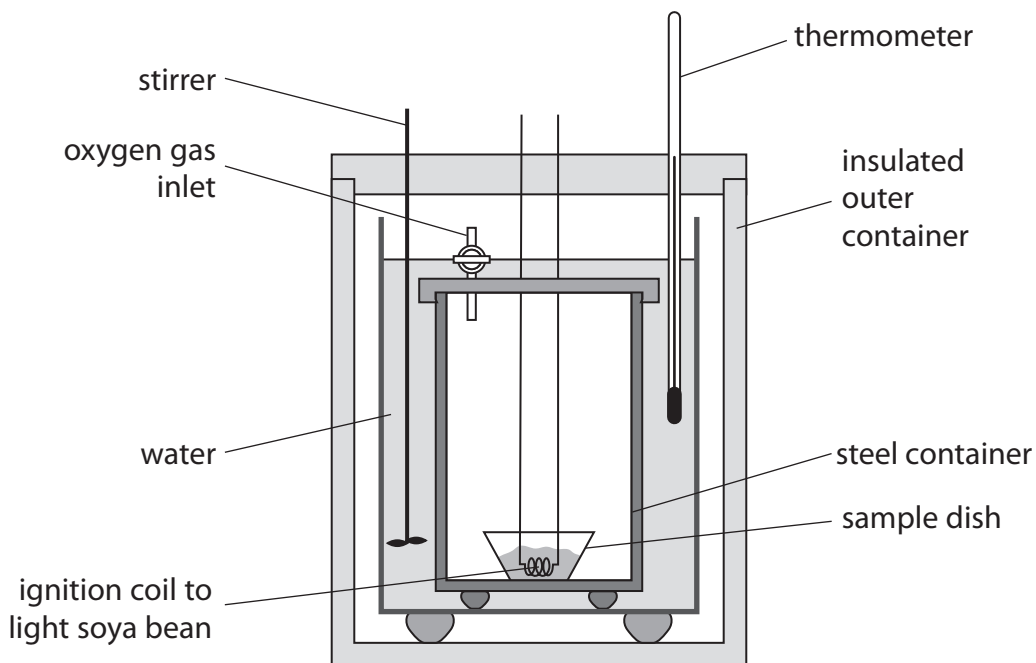

Explain two reasons why this apparatus will give a more accurate energy value than the apparatus used by the student.

(4)

1

.....

.....

2

.....

.....

.....

(Total for Question 4 = 11 marks)

DO NOT WRITE IN THIS AREA

DO NOT WRITE IN THIS AREA

DO NOT WRITE IN THIS AREA



P 7 2 4 7 3 A 0 1 3 2 0

5 (a) The graph shows the change in area of rainforest on the Earth from 1990 to 2015.

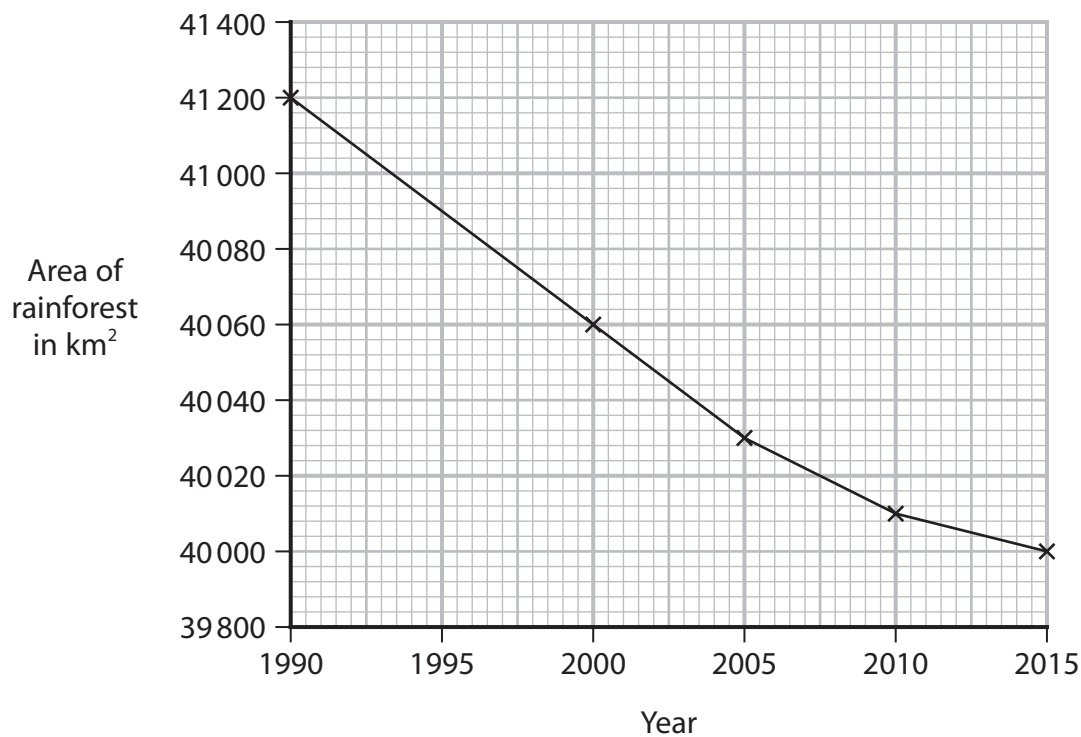

(i) Determine the mean rate of decrease of rainforest area, in km² per year, from 1990 to 2015.

(2)

mean rate of decrease = km² per year



(ii) Loss of rainforests causes an increase in atmospheric carbon dioxide gas.

Explain the negative effects of an increase in atmospheric carbon dioxide gas.

(3)

.....

.....

.....

.....

.....

.....

.....

.....

DO NOT WRITE IN THIS AREA

DO NOT WRITE IN THIS AREA

DO NOT WRITE IN THIS AREA



- (b) Scientists investigated the effect of deforestation on a river. The river flows through a forest, part of which has been deforested.

The graphs show the changes in nitrate concentration and the biodiversity of animals in the river as it flows through the forest.

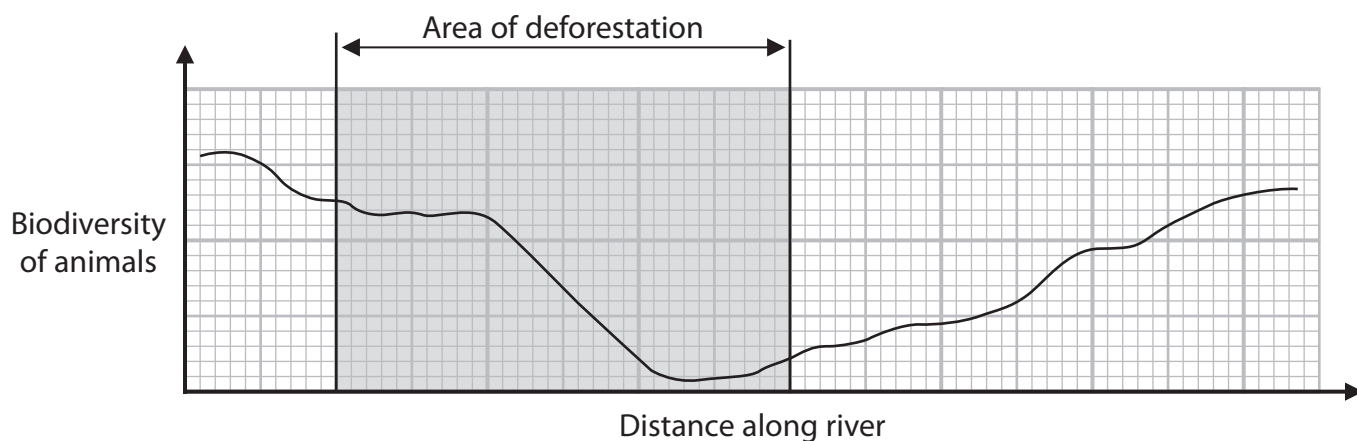
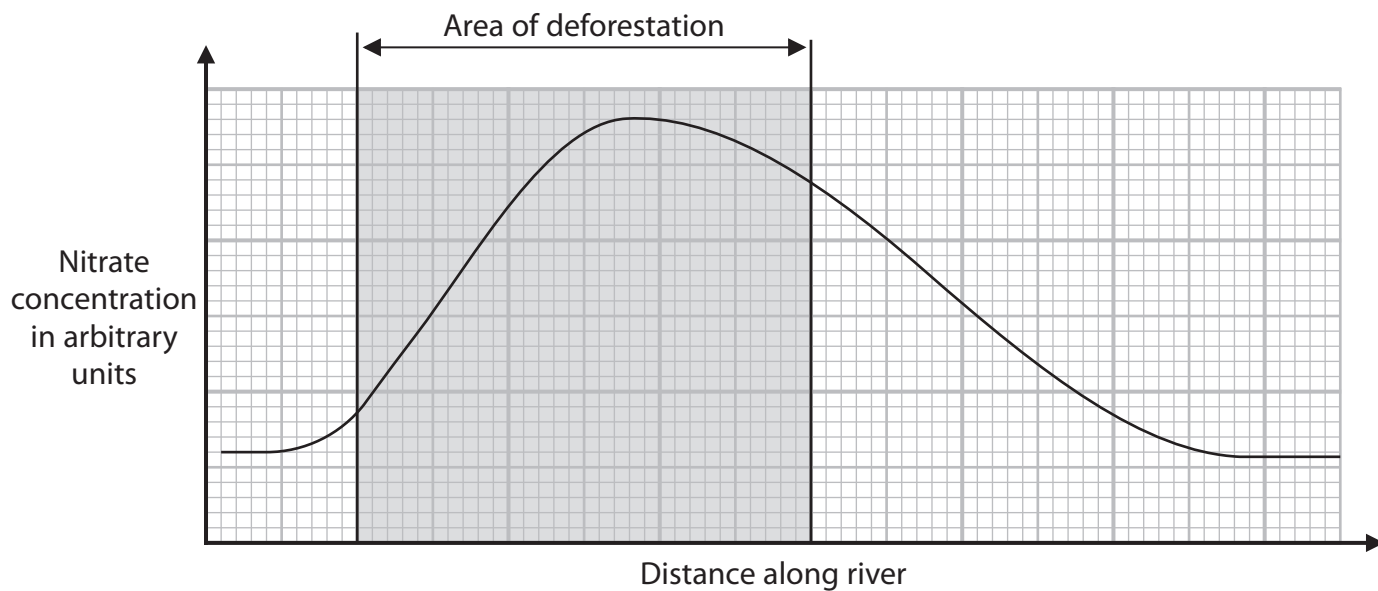

- (i) Describe the role of microorganisms in the conversion of organic waste into nitrate ions in the river.

(3)

.....

.....

.....

.....

.....

.....



(ii) The number of different animal species living in the river was recorded as a measure of the biodiversity of animals.

Give a reason why this may not be a complete measure of biodiversity.

(1)

(iii) Explain the change in the biodiversity of animals along the river.

Use information from the graphs in your answer.

(4)

(Total for Question 5 = 13 marks)

DO NOT WRITE IN THIS AREA

DO NOT WRITE IN THIS AREA

DO NOT WRITE IN THIS AREA



P 7 2 4 7 3 A 0 1 7 2 0

6 Rabies is a dangerous disease caused by a virus.

(a) The rabies virus is a pathogen.

Which other groups of microorganisms include pathogens?

(1)

- A bacteria and fungi only
- B bacteria, fungi, and protocists
- C bacteria and protocists only
- D fungi and protocists only

(b) Rabies is transmitted to humans when they are bitten by an infected animal. Domestic dogs are dogs kept by people as pets or as working animals. Dogs and some wild animals are known to transfer rabies to humans.

In the 1940s, a rabies vaccine for animals was introduced in the United States and most domestic dogs were vaccinated.

The graph shows the number of cases of human rabies and domestic dog rabies in the United States from 1938 to 2018.

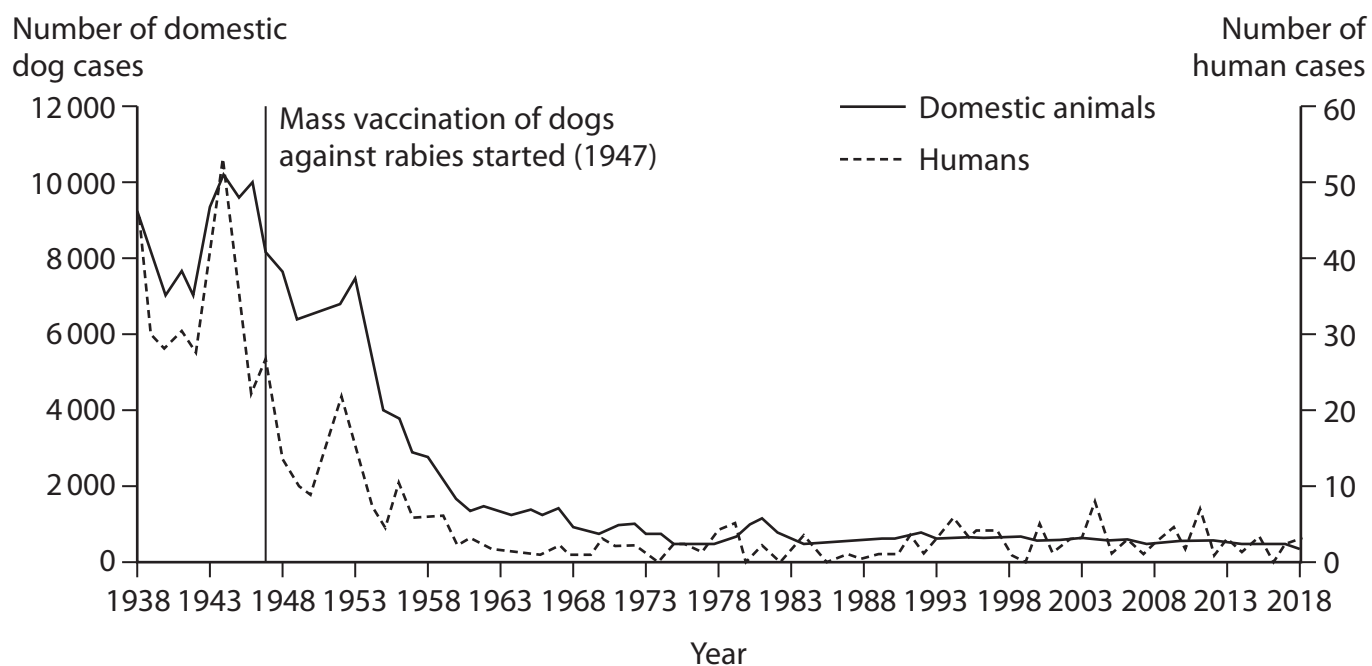

- (i) The immune system of dogs works in a similar way to the immune system of humans.

Explain how the rabies vaccine prevents dogs from developing rabies.

(3)

- (ii) Discuss the effects of the use of the rabies vaccine to immunise domestic dogs on the number of cases of rabies in humans.

Use information from the graph to support your answer.

(4)

DO NOT WRITE IN THIS AREA

DO NOT WRITE IN THIS AREA

DO NOT WRITE IN THIS AREA



P 7 2 4 7 3 A 0 1 9 2 0

(iii) A new RNA vaccine is being developed to treat rabies.

RNA that codes for parts of the rabies virus protein coat are injected into the body. Cells then take up the RNA and produce the viral proteins.

Describe how the cells use the RNA to produce the viral proteins.

(4)

.....

.....

.....

.....

.....

.....

.....

.....

.....

.....

.....

(Total for Question 6 = 12 marks)

TOTAL FOR PAPER = 70 MARKS

DO NOT WRITE IN THIS AREA

DO NOT WRITE IN THIS AREA

DO NOT WRITE IN THIS AREA

